



A PRIMER ON SELECTING PRINTERS FOR EMBEDDED APPLICATIONS

Introduction

Thermal printers are pervasive in our daily routines. Gas pumps, point of sale systems, and ATMs all issue receipts. Airlines provide boarding passes. And, virtually all shipping labels include bar codes. Thermal printing technology carries the bulk of the workload in each of these printing applications, because it delivers high reliability, low maintenance, competitive performance, and excellent resolution. And, because of these same attributes, designers are relying on thermal printouts for increasingly innovative applications, such as generating traffic citations from wireless devices mounted on police motorcycles, providing EKG printouts for physicians to track irregular cardiac behavior, and producing mandatory documentation for electronic voting systems.

This white paper examines the printer technologies that are available for embedded applications, explains why direct thermal technology is ideal for embedded usage, provides selection criteria for identifying the right thermal printer, and demonstrates the value of engaging the printer manufacturer early in the design cycle. These insights will help technical teams evaluate the specifications for the available alternatives and ultimately make printing system projects more successful.

Embedded Applications Have Unique Printer Needs

For the purposes of this paper, a printer for an embedded application is defined as being fully integrated within the chassis of another computer-based product—as opposed to a standalone printer. Examples of embedded applications include kiosks, ATMs, voting machines, certain test and measurement equipment, and many medical devices.

For system designers who must choose a printer supplier for embedded applications, the following concerns are paramount:

1. Minimize the incremental cost of the printer, to help meet overall system cost targets.
2. Satisfy key mechanical, electrical, and software integration needs.
3. Fulfill specific performance and output delivery requirements.
4. Meet application specific output requirements, such as dimensions and resolution.
5. Maximize reliability and minimize the need for routine or unexpected maintenance.
6. Provide system monitoring and problem notification capabilities.
7. Ensure that critical manufacturing requirements are addressed.

Selecting the Right Printer Technology

There are four primary types of printing technology available today: direct thermal printing, thermal transfer printing, impact printing, and laser printing.

Direct Thermal Printing

Direct thermal printing employs a print head with regularly spaced electrodes to create an image on specially treated paper. In operation, conduction of electrical signals, in an array of tiny gaps between electrodes, applies heat to the substrate. A chemical reaction, created by the applied energy, forms small dots that comprise text or graphical images. Historically, thermal paper supported limited longevity, particularly when exposed to heat or direct sunlight. Recent advances, however, include products formulated to last up to 25 years, under the right storage conditions. Direct thermal printers have a small number of moving parts, which bolsters mechanical reliability, and only paper is consumed in the printing process.

Thermal Transfer Printing

Like direct thermal, thermal transfer technology employs a thermal print head to create an image on a substrate. In operation, ink is transferred from a ribbon to the substrate. Therefore, additional components include a ribbon supply and take-up mechanism, and ribbon, which must be replaced after use. Thermal dye transfer printers that produce high-quality photo images are special adaptations of this technology.

Impact Printing (also known as Dot Matrix)

Impact printers use a moving hammer to transfer ink from a ribbon onto paper. The impact enables these devices to print multi-part forms, automatically generating several copies of a document simultaneously. Because of the moving parts involved, impact printer lifetime can be limited and maintenance costs higher relative to thermal printers. Paper and ribbons make up the consumables for this class of devices.

Laser Printing

Laser printers use digital copier technology to inscribe an image on a drum, which is then transferred to paper using toners. In general, laser printing engines are bulkier than other printing technologies and are generally considered expensive to operate. Consumables here include paper and toner cartridges.

This paper focuses on direct thermal printing technology as the ideal choice for embedded systems developers—particularly when designing for unattended applications. Direct thermal printing technology satisfies embedded systems requirements because it has comparatively high reliability ratings, minimal maintenance requirements, less frequent need to replace consumables, competitive print speeds, and the flexibility to print on a variety of media.

Meeting Cost Targets

A number of factors can significantly influence the cost of an embedded printing project. These include: form factor, customization needs, system integration timelines, system manufacturing requirements, and maintenance needs. The considerations for these variables are discussed throughout this paper to give you a better understanding of the alternatives and trade-offs.

In general, when faced with rigid cost parameters, it is advisable to consult with the printer manufacturer as early as is feasible in the design cycle. By doing so, you will have more opportunity to assess the alternatives, to optimize the system design for costs, and to avoid design missteps that can adversely affect your project's budget or release schedule.

Mechanical, Electrical, and Software Integration

A fundamental hardware design issue for an embedded application involves form factor. Generally, there are four basic alternatives: a printer mechanism with application specific integrated circuit (ASIC), a printer mechanism with controller board, a panel-mount thermal printer, and a kiosk printer.

Printer Mechanism with Application Specific Integrated Circuit (ASIC)

The printer mechanism is typically comprised of head pressure spring, thermal head, stepper motor, platen roller, and sensors. For a complete solution, a mounting design, controller board, and interface cable are required. Clearly, this ASIC-based solution offers the greatest design flexibility. But, it also requires the most design work, based on the number of components that must successfully work together. This choice is generally favorable when the entire system must operate using one board, due to spatial limitations, but it requires significantly more technology expertise and design time. Volume production savings will often exceed the cost of added integration work.

Printer Mechanism with Controller Board

This option includes the same mechanism described above, paired with a fully populated controller board, including CPU.

For mechanism-based designs, the application or overall mechanical design may dictate whether a straight or curved paper path is required. For example, a straight path is generally necessary to accommodate peel-off label stock (see Figure 1).

Figure 1. Curved and straight paper path options for thermal printer mechanisms.

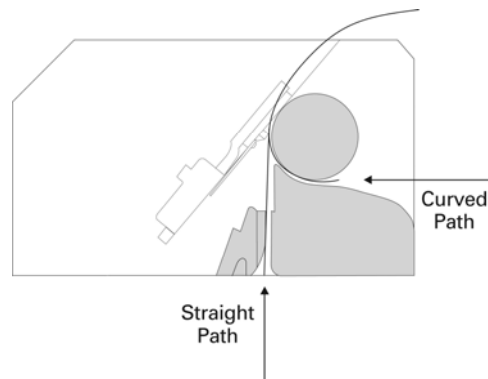

Panel-Mount Thermal Printer

Panel-mount thermal printers offer a more complete low voltage embedded printing solution that is slotted into the front panel of a device. These units include the printer mechanism, paper well, tear bar, printer housing, and external faceplate. By reducing the amount of integration work required, a panel-mount printer can offer a highly useful alternative to the standard mechanism approach. Seiko Instruments Inc. panel-mount designs also include the front-loading EZOP™ platen release feature to provide maximum utility.

Figure 2. Three steps to replace a paper roll with the EZOP™ platen release design.

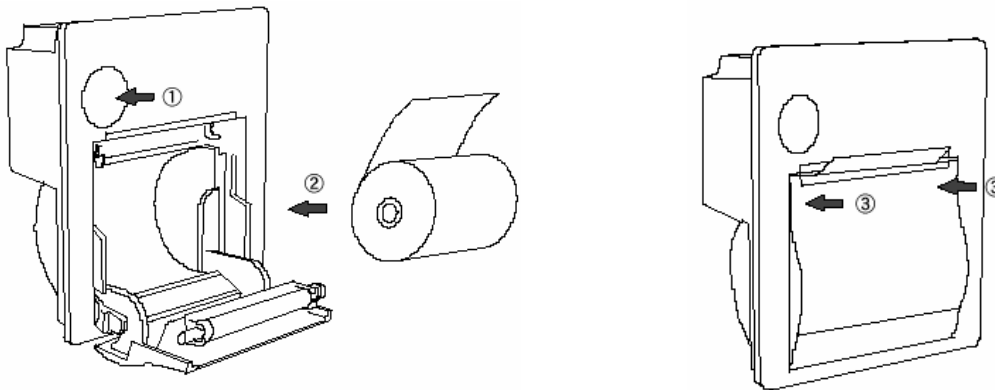

Kiosk Printer

A kiosk printer includes the printer mechanism, controller board, paper holder, and a cable, contained in an open bracket ready for installation in the final product. Other components can include: a spring-mounted tension roller to accommodate large paper rolls, an automatic cutter for trimming the output from the continuous paper supply, a looping presenter that prevents the user from pulling the paper and disrupting the printing process, and sensors for detecting low paper supply or other problems.

A kiosk printer generally offers the designer plug-and-play capability, and it is the most direct route to a successful embedded printing solution. The fixed dimensions of a kiosk printer will consume a certain amount of real estate. This should be planned for in advance. Seiko Instruments kiosk printers, such as the APU-9000C series help mitigate this issue with comparatively small footprint designs.

High transaction volume applications, such as “through-the-wall” ATMs, often require very large, 10-inch diameter paper rolls. When a large diameter paper roll is necessary, adequate depth and paper replacement access should be incorporated into the system design.

Electrical and Software Integration

To address electrical integration, you should select the printer mechanism and controller combination that matches the power and voltage levels you have available in your application. Most high performance thermal printer mechanisms require a nominal 24-volt source to provide the electrical discharges to mark the paper. This often requires the addition of a DC/DC step-up converter or other power supply. Portable devices can operate from as little as 5 volts. In addition, the controller will require a well-regulated 3 to 5-volt DC source to power the on-board electronics that control the mechanism.

Thermal printer power consumption is generally quite reasonable, and usually will not exceed normal power consumption expectations for modern electronic products. Special heat sinking equipment is generally not required for the printer, nor are special cooling capabilities, other than a standard system fan that moves air through the chassis to cool other system components.

The interface that moves data from the host computing system to the printer controller, and ultimately to the thermal print head itself, is another important area for electrical integration. The most common hard-wired interface options include: serial links (RS-232, TTL), parallel ports, Universal Serial Bus (USB), and, in some cases, Ethernet. Wireless interfaces, such as Bluetooth and Wi-Fi, are typically used in portable, standalone printer applications, and not in embedded solutions.

Software integration is primarily dependent on the availability of appropriate printer driver software or host-based software to issue printing instructions. Many widely used operating systems, including Windows, Linux, and JPOS, incorporate a printing system for a printer driver to interact with to produce the desired output. For operating systems that do not have a printing system, such as Windows CE, the manufacturer should provide a software development kit (SDK) to facilitate integration.

Fulfilling Performance and Output Delivery Requirements

Printer performance varies based on a number of factors. Designers should expect some correlation between performance and operating voltage, cost, and, to some extent, mechanical dimensions—faster printers typically require larger motors. Generally, an embedded thermal printer running at ten inches per second, or three inches per second for a portable application, is considered a higher performance device.

Thermal printers offer a number of output delivery options, including a manual tear bar and an automatic cutter for separating the output. For unattended applications, it may be desirable to incorporate a looping presenter, with an automatic cutter, to prevent

users from pulling paper during the printing process. This can help to avoid unintended disruptions and potential maintenance issues. A partial auto cutter, combined with a receipt retractor, presents another alternative. With this configuration, the system can be programmed to withdraw the receipt to a holding area, if a specific time interval has passed and the receipt has not been removed by the user. This avoids littering the immediate area.

Other examples of application-specific delivery capabilities include: a built-in label “peeler,” to ease the manual effort required by the user when printing in large volumes; and a sensor or control mechanism that limits the flow of printed labels. The sensor capability helps the user by only dispatching a new label when the previous output is removed.

Meeting Application-Specific Media Requirements

Direct thermal printouts are available in various sizes. However, most applications involve labels, receipts and other output that are no more than 4 inches wide (approximately 112 mm). Typically, direct thermal applications only require black text or graphics. Multi-colored printouts can be created by varying the level of energy applied to specially coated thermo-sensitive paper.

Thermal printing technology can be used with a range of substrate thicknesses. To ensure success, it is critical to choose a printer that is rated for the appropriate media thickness and to only use paper that has been qualified by the manufacturer. As a caveat, however, note that some vendors may only qualify their own proprietary formats for labels and other substrates, as a means of ensuring residual sales.

Other important output criteria include:

Output Resolution

Current thermal printing technology can support up to 600 dots per inch (DPI), although the vast majority of applications can be addressed more cost effectively with 203-300 DPI printers.

Fonts

Virtually all thermal printers come with a selection of standard fonts built into the controller firmware. For example, there are currently an array of one and two-dimensional bar code format options in the Seiko Instruments Inc. printer firmware library. The bar code format can be selected by sending the corresponding ID number for the desired code.

Graphics

Commonly used image file formats, such a JPEG or bitmap can be used with a thermal printer to produce, for example, a coupon or company logo. Although, very high resolution files can affect printing performance. The paper converter or manufacturer should be consulted when pre-printed security marks are needed, or to help address other more elaborate paper requirements.

Maximizing Reliability and Minimizing the Need for Maintenance

A long and trouble-free operating life expectancy is a key factor in selecting a thermal printer. While the individual lifetimes cannot be accurately predicted for any device, certain specifications can be used to gauge product reliability. These include a:

- Minimum rating for the number of total dots produced by the print head (measured in electronic pulses). 150 million pulses is considered a very high rating for a 24-volt printer.
- Minimum rating for total length of output that can be produced (in kilometers). 150 kilometers of total printing is considered a high rating for a 24-volt printer.
- Minimum rating for total number of cuts. A 1-million-cut rating generally indicates a very durable auto-cutter.

Durability may also be a key factor for particular applications. For example, you may need to plan for a shock-mounted design to ensure continued operation after repeated drops from a specific height to a concrete surface. Similarly, environmental specifications for humidity and ambient temperature will help you judge whether the printer will perform reliably on a cold winter day in Minnesota or a hot, muggy day in Florida, without special protection.

Providing System Monitoring and Problem Notification Capability

As with any electronic devices, thermal printers cannot be built to run in perpetuity. Paper replacements are periodically necessary, and unattended systems can be subject to extreme conditions or mistreatment by users. To reduce potential problems and downtime, printer monitoring provides signals to the host computer system for important conditions such as “paper low,” “paper jam,” and “paper out.” The host system can then alert a remote maintenance facility to correct the problem, providing improved uptime and a better overall user experience.

Ensuring Critical Manufacturing Requirements Are Addressed

The reputation of the thermal printer manufacturer for quality and on-time delivery is an important factor in vendor selection. Although all vendors will make claims in this area, a careful assessment of these capabilities will pay dividends.

If you export your final product, you must identify a product that is fully compliant with European Union RoHS requirements for the elimination of hazardous substances, and other region-specific compliance regulations.

Ease of integration into your manufacturing process should also be carefully assessed. For example, as an alternative to manually setting printer specifications, such as interface type and paper thickness, Seiko instruments Inc. offers a setup utility for Uploading a file with these settings. By automating this process, the setup utility can avoid the time required to effect the settings manually or to develop a similar utility internally, representing a significant cost savings.

Conclusion

Direct thermal printing technology provides the ideal solution for embedded system printing applications of all stripes, such as kiosks, ATMs, voting systems, test and measurement devices, and medical equipment. By engaging the printer manufacturer in advance, to explore the issues raised in this paper, you can significantly bolster the return on your investment and minimize project risk, even for the most complex and demanding systems. By deploying a highly reliable product from a manufacturer with a reputation for design and manufacturing excellence, you are sure to maximize the overall user experience and avoid unnecessary long-term maintenance costs.

About Seiko Instruments

As a member of The Seiko Group, Seiko Instruments (SII) represents a globally recognized brand, embodying innovative design and precision manufacturing excellence. Founded in 1937, SII manufactures and markets electronic components, thermal and specialty printers, consumer electronics, communication and network technology, scientific instrumentation, and precision manufacturing technology. SII has a global presence, with more than 13,000 employees worldwide.

For more information about Seiko instruments [kiosk printers](#), [mobile printers](#), [portable printers](#), [receipt printers](#), [POS printers](#), [point of sale printers](#), and [thermal printer mechanisms](#) please visit our web site at <http://www.siiprinters.com> or call us at 877-905-2291.